



FritsJurgens®

FritsJurgens Pivot Door System

technical documentation

FRITSJURGENS MPDS-S80 RVS F9000-SERIES

INDEX

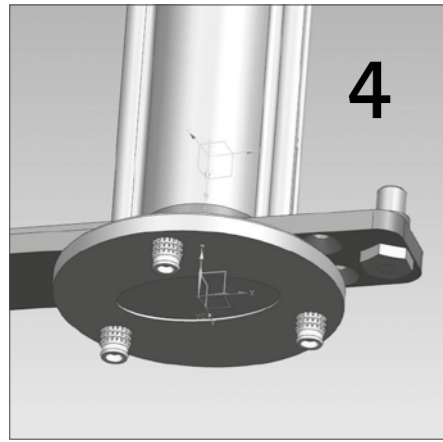

PRODUCT DESCRIPTION



CONTENT OF HINGE PACKAGE

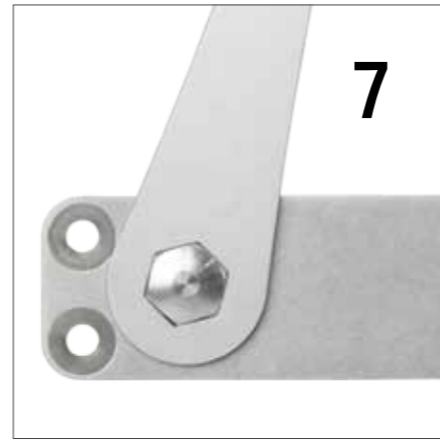

SETTING OPTIONS

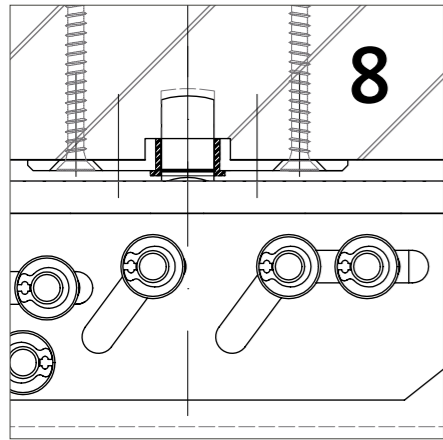

TECHNICAL DRAWINGS



OPTIONAL PRODUCTS

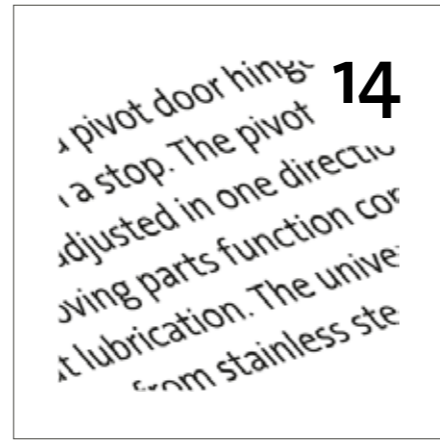

SPECIFICATION/NOTES

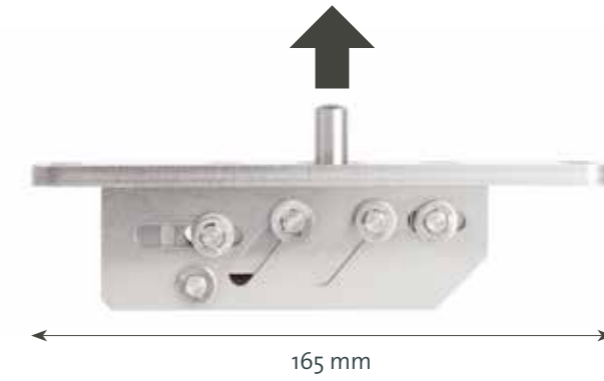
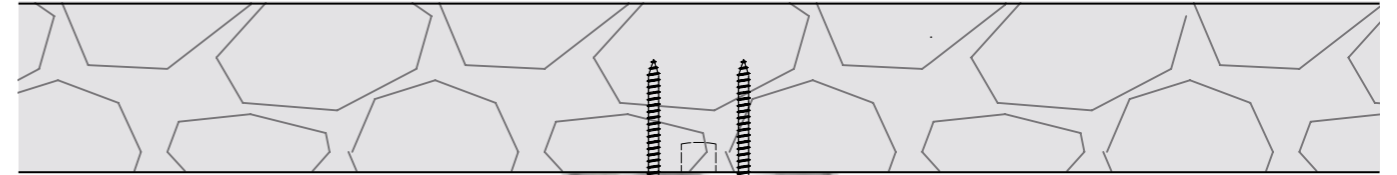

PRODUCT DESCRIPTION

The FritsJurgens pivot door hinge stands out because all the technology is fitted in the door. This makes the interface with the floor subtle and stylish.

It is a pivot door hinge with a hold position at 90° and -90°. FritsJurgens pivot door hinges can be used with swing doors and doors with a stop up to a maximum weight of 500 kg and a maximum width of 2,000 mm from the pivot point to the end of the door. Can be used for door thicknesses upwards of 40 mm.

Nothing in the floor or in the ceiling



All the door technology is fitted in the door not in the floor. As the top pivot is also fitted in the door, no recess needs to be made in the ceiling.

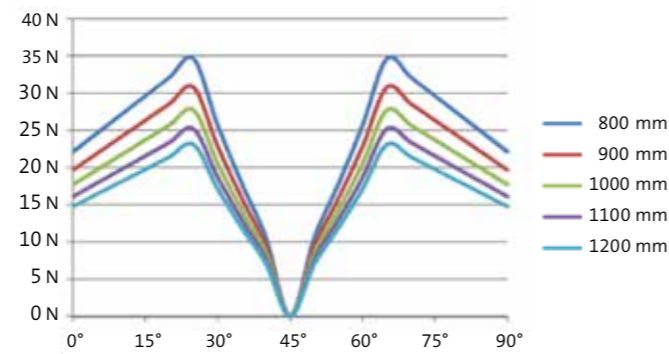

Self-closing hold positions

A beautiful door requires good technology. Self-closing with a hold position every ninety degrees. Which means you no longer need spring latches, cranks, frames or slats.

Very high bearing capacity

500 kg

It is technically possible to achieve high bearing capacities by using floating bearings that are manufactured using very wear-resistant polymers and are improved by the addition of reinforcement materials and solid lubricants geared precisely to each other. Which means that large pivot doors are not a problem.

Maintenance-freesystem

136 years

Thanks to the use of very high-quality materials the system is maintenance-free. Opened and closed one million times, equating to 136 years' intensive use. The system is also fully manufactured from materials with a high corrosion-resistance.



The unique characteristics

- No devices need to be fitted in the structural framework
- Door can be fitted afterwards
- Can be used in situations with underfloor heating
- All the main functions have been integrated
- Tested, robust construction for doors weighing up to a max. of 500 kg

40 mm Standard door thickness

The FritsJurgens pivot door system can be used with doors upwards of 40mm thick. Standard doors, exceptional manufacture.



Simple, fast fitting

The use of the unique ceiling and floor plate makes the fitting of a pivot simple. FritsJurgens pivot doors are positioned between a floor plate and a ceiling plate that are fitted to the finished floor and the finished ceiling.

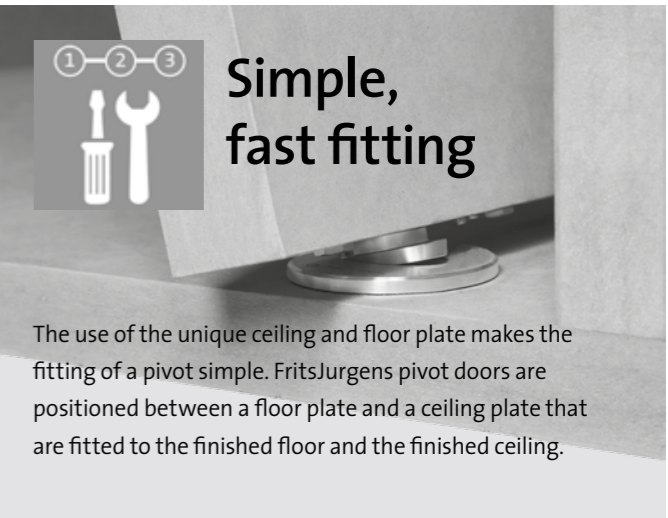

Applicable on each floor

1 N/mm²

The FritsJurgens pivot door stands on a floor plate Ø80mm and gives a pressure (FW) of 1 N/mm, oak has a compressive strength (Fw) of 50 N/mm. Common screeds have a minimum compressive strength (Fw) of 12 N/mm. For specific floors we refer to the specifications of the manufacturer.

Every door - its own "motor"

Every door has to work optimally regardless of the weight of the door or its size. So we have developed a mechanical drive unit in four different strengths so that every door up to 200kg remains in the hold position and closes with a good spring action. Every weight - its own "motor". All variants of the MPDS-S80 F9000-serie have secured positions at 0°, 90° and -90°, the same geometry and fit into the same slot in the door. The pivot door systems have a load capacity of 500 kg.



MPDS-S80 RVS F9000-SERIES	MAXIMUM WEIGHT (KG)	MAXIMUM WEIGHT AT GUARANTEED CLOSING FORCE (KG)	MAXIMUM DOOR WIDTH (MM)
MPDS-S80 RVS F9016	500	to 40	up to 650
MPDS-S80 RVS F9020	500	to 70	from 650 to 800
MPDS-S80 RVS F9024	500	to 110	from 800 to 1000
MPDS-S80 RVS F9028	500	up to 200	from 1000 to 1500*

* Wider doors are possible, closing force decreases.

For particularly high doors, heavy doors and / or constant headwind or overpressure in closing doors, you have to take one pivot door strength higher as usual.

CONTENT OF HINGE PACKAGE

Bottom pivot The Fritsjurgens MPDS-S80 RVS F9000-series contains all the elements needed to hang 1 pivot door.

Quantity	Part	Description
1 Item	MPDS-F9000-SERIES (9016/9020/9024/9028)	Bottom pivot
1 Item	MPDS-AT-C-9001	Top pivot
1 Item	PPR80-B01	Ceiling plate
1 Item	VPR80-B01	Floor plate
1 Item	S01	Adjustment spanner
1 Item	Fitting template 95 mm	
1 Tube	Fitting adhesive	
1 Item	Fitting instructions	
1 Item	Allen wrench	



SETTING OPTIONS

Bottom pivot

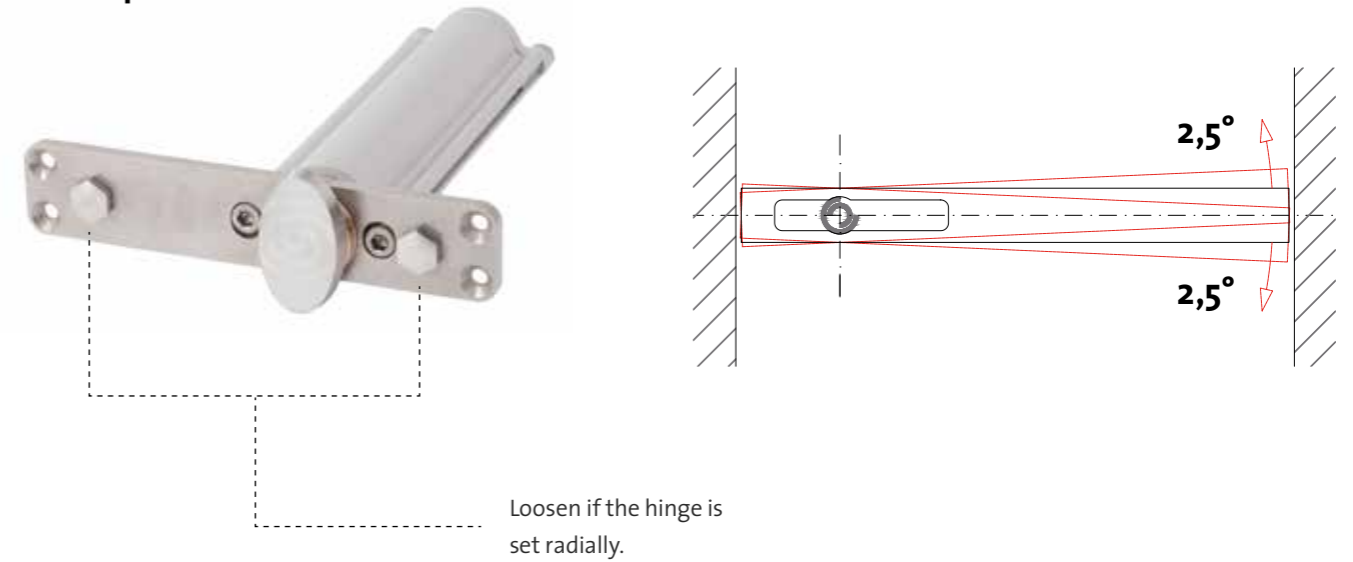

Top pivot

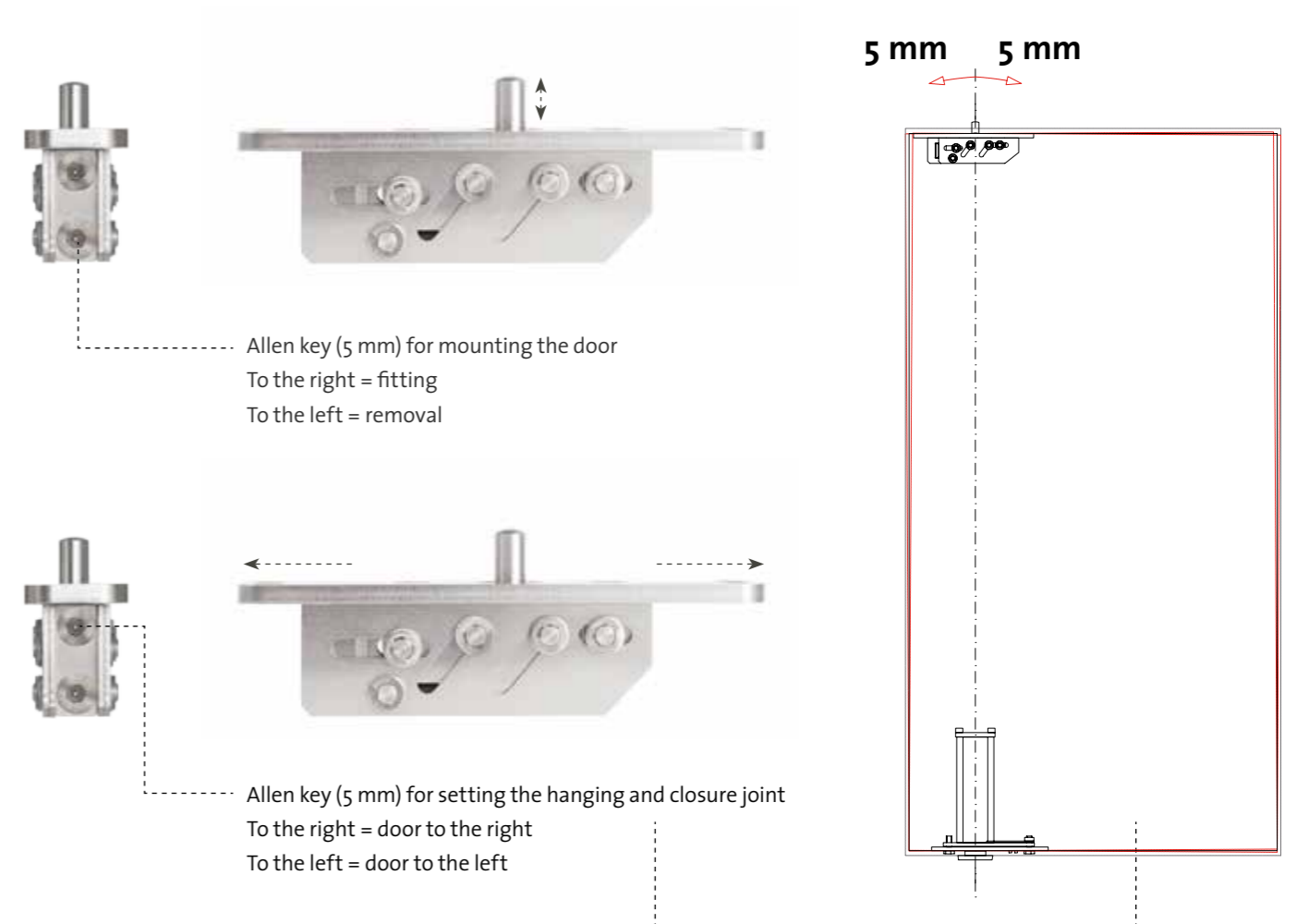

TECHNICAL DRAWINGS

Bottom pivot MPDS-F9000-SERIES (9016/9020/9024/9028)

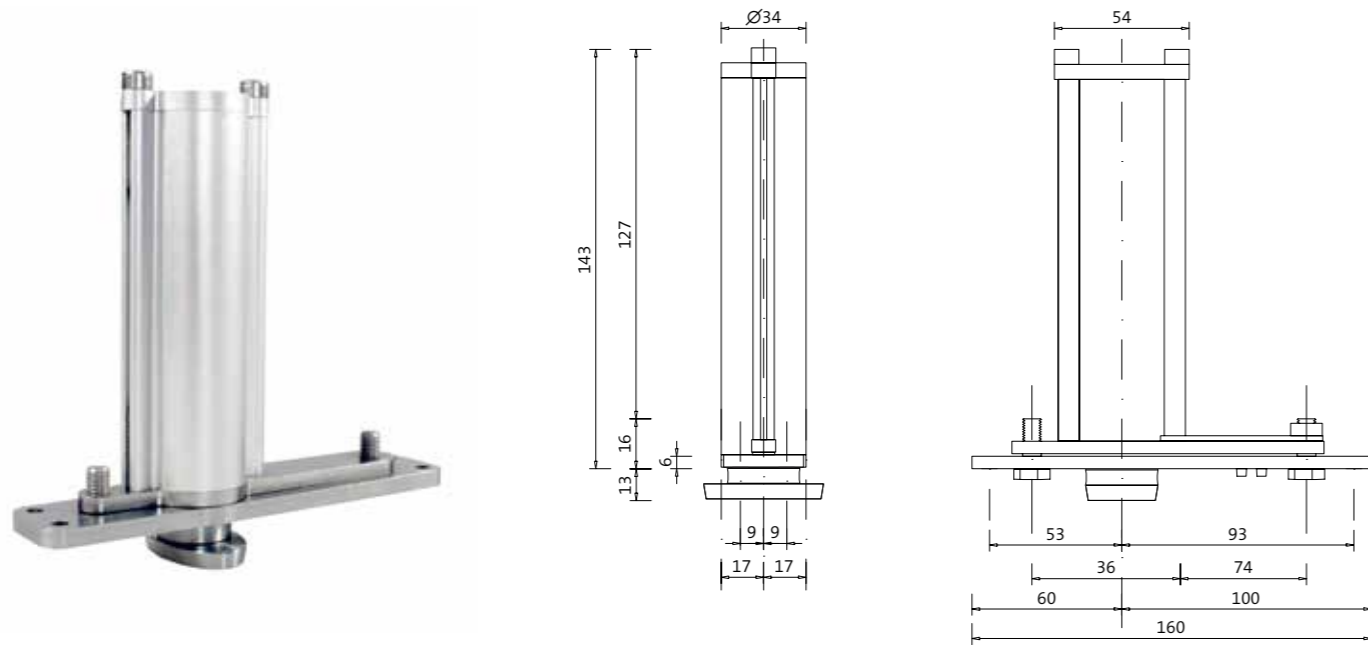

CUTTING DRAWING

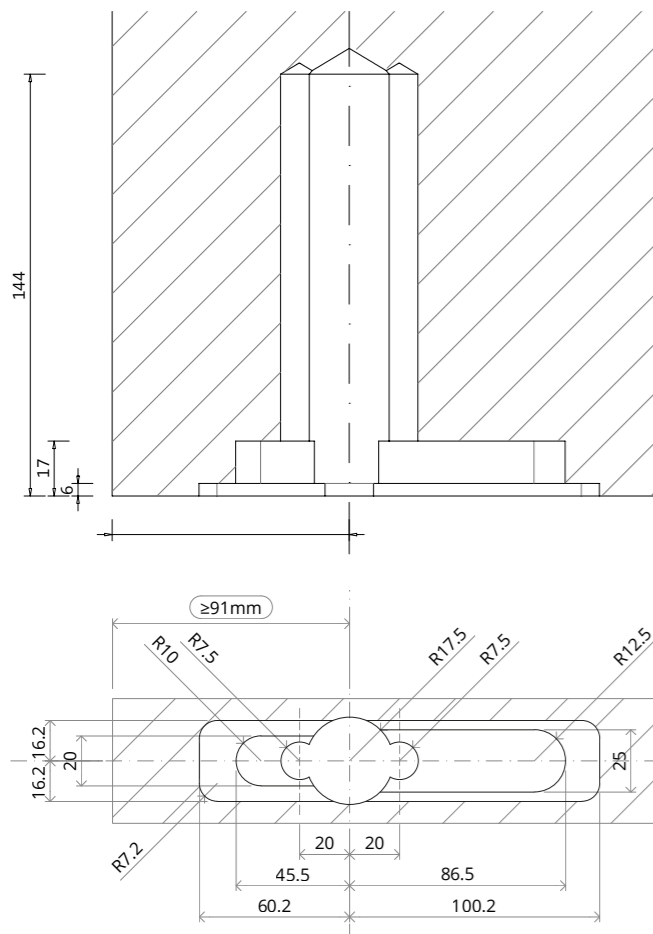

DIMENSIONS AROUND DOOR

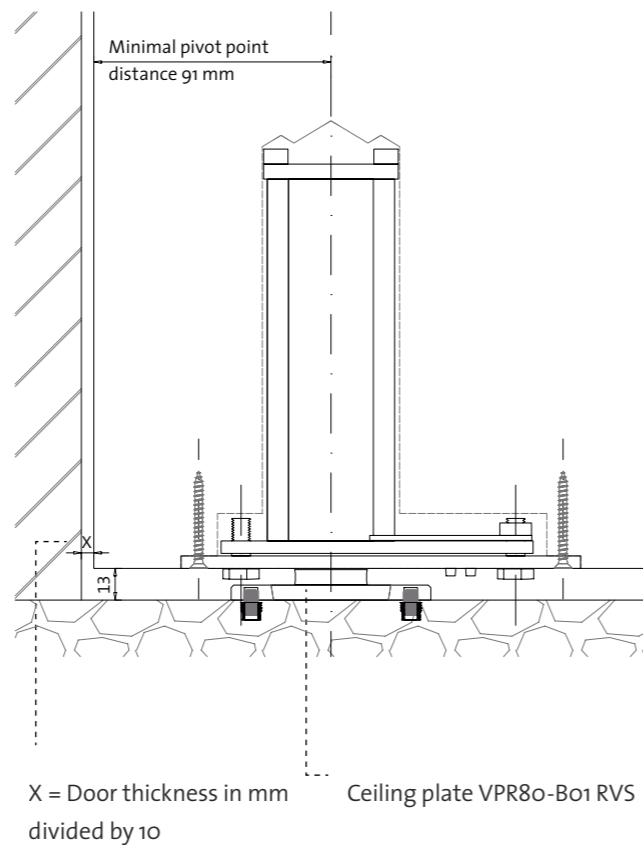

Top pivot MPDS-ATC-9001

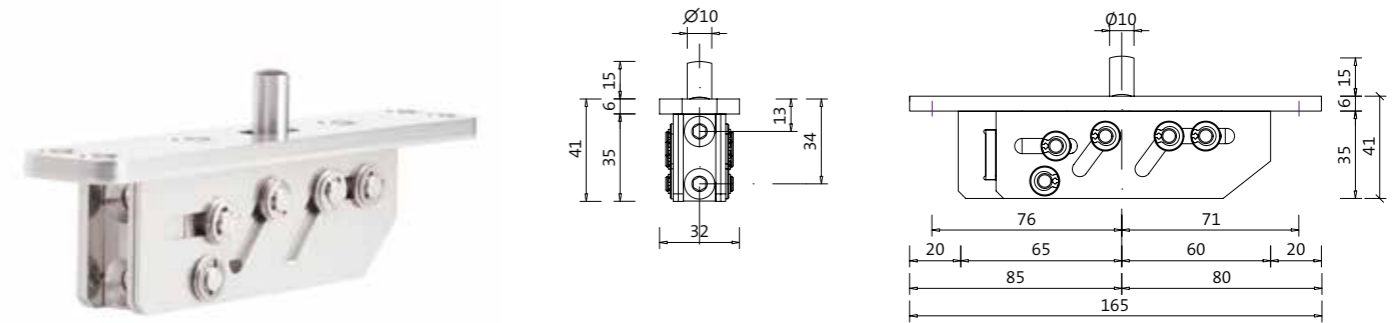

CUTTING DRAWING

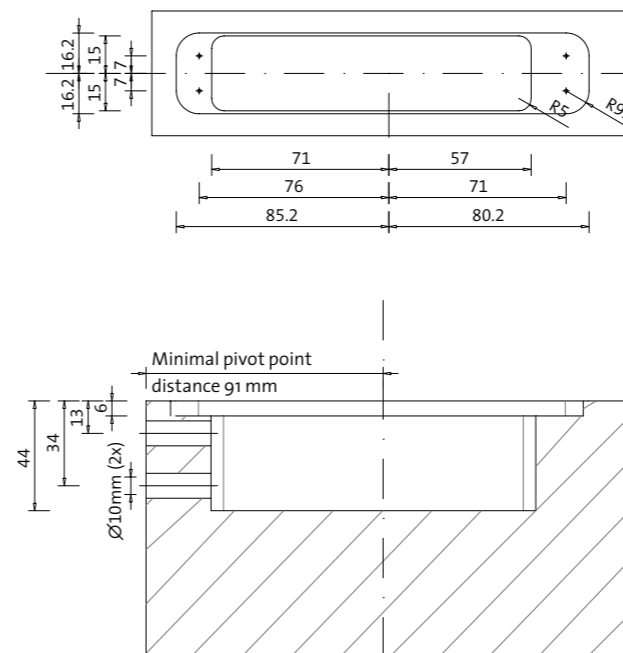

DIMENSIONS AROUND DOOR

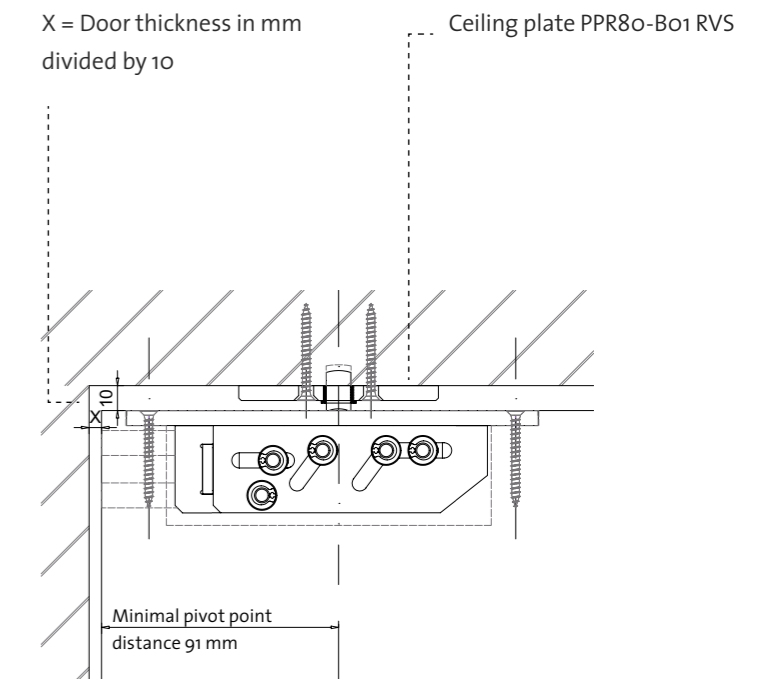

Ceiling plate PPR80-B01 RVS

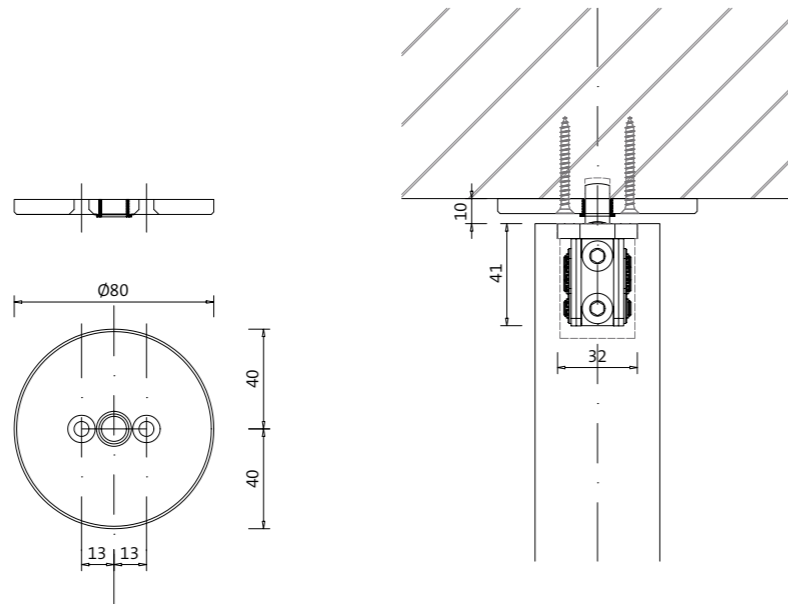

Floor plate VPR80-B01 RVS

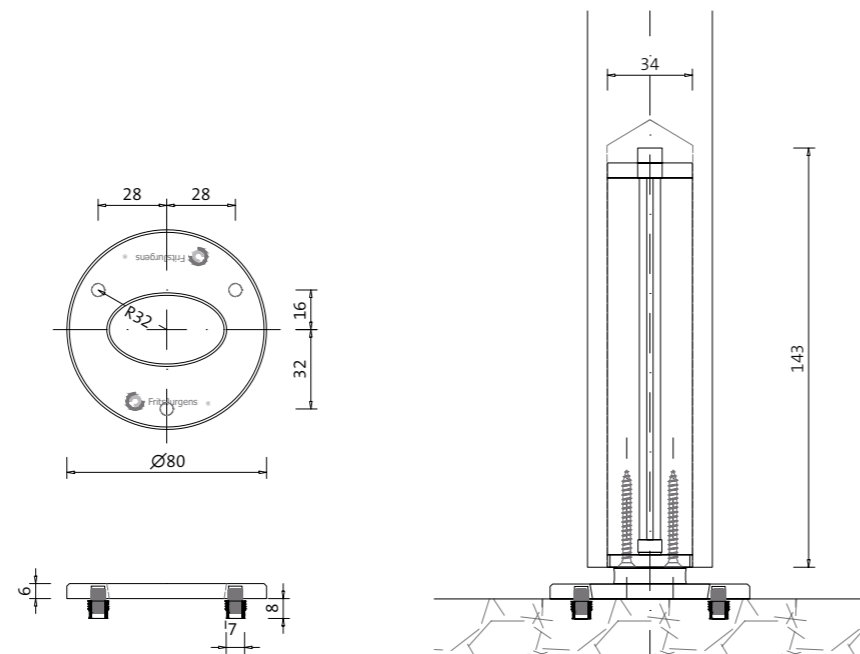

OPTIONAL PRODUCTS

Article nr.	Element	Beschreibung
300352	FRITSJURGENS PP 40*60-B11 RVS	Ceiling plate 40*60mm 2mm thick BELGIAN
400601	FRITSJURGENS VP 80*40-B11 RVS	Floor plate 80*40mm 6mm thick BELGIAN
300352	FRITSJURGENS PP 40*60-B11 RVS	Ceiling plate 40*60mm 2mm thick EXTERIOR
400501	FRITSJURGENS VP 82*52-B01 RVS	Floor plate 82*52 6mm thick EXTERIOR

Ceiling plate PP40*60-B11 RVS

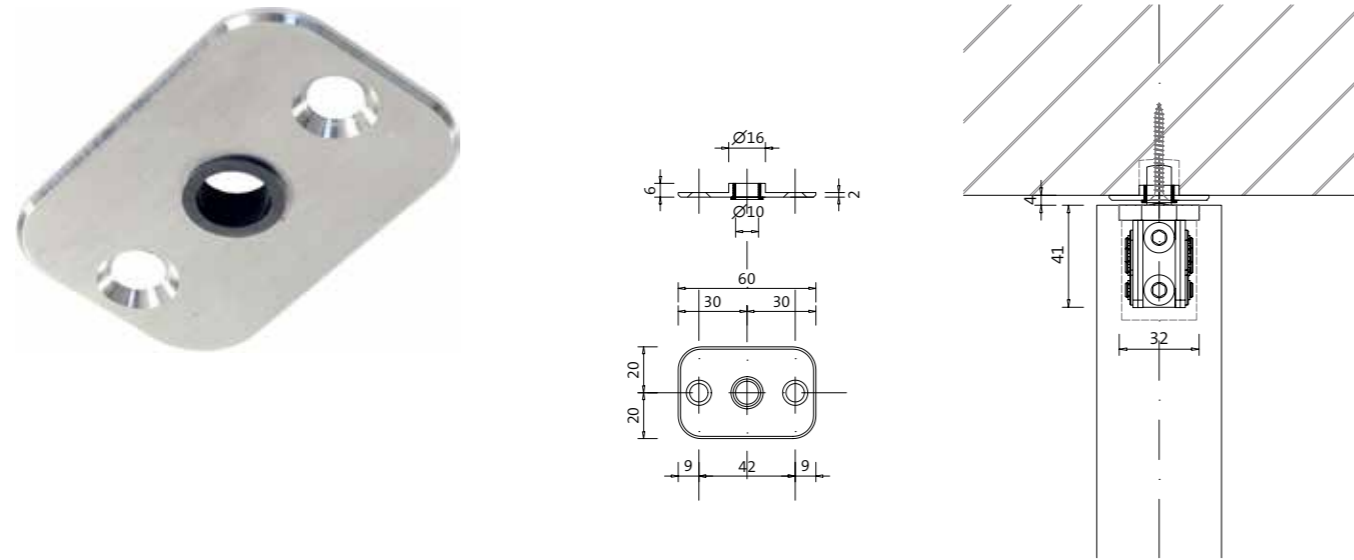

Ceiling plate PP40*60-B11 RVS

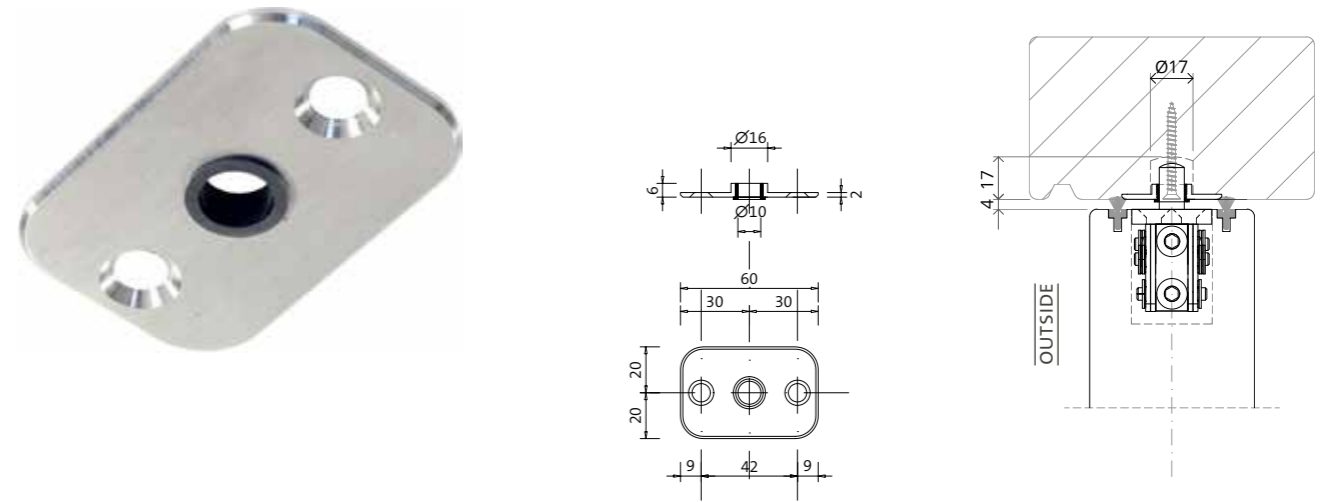

Ceiling plate PPR80-B01 RVS

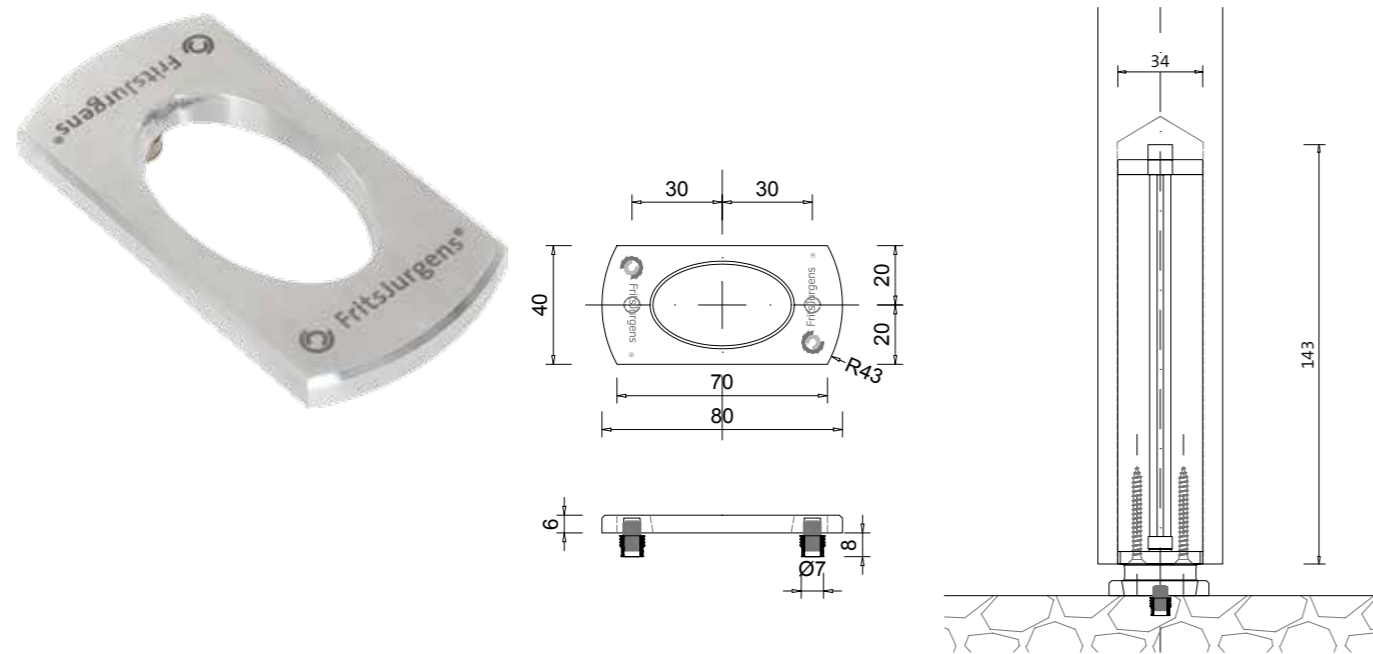

Floor plate VP 82*52-B01 RVS

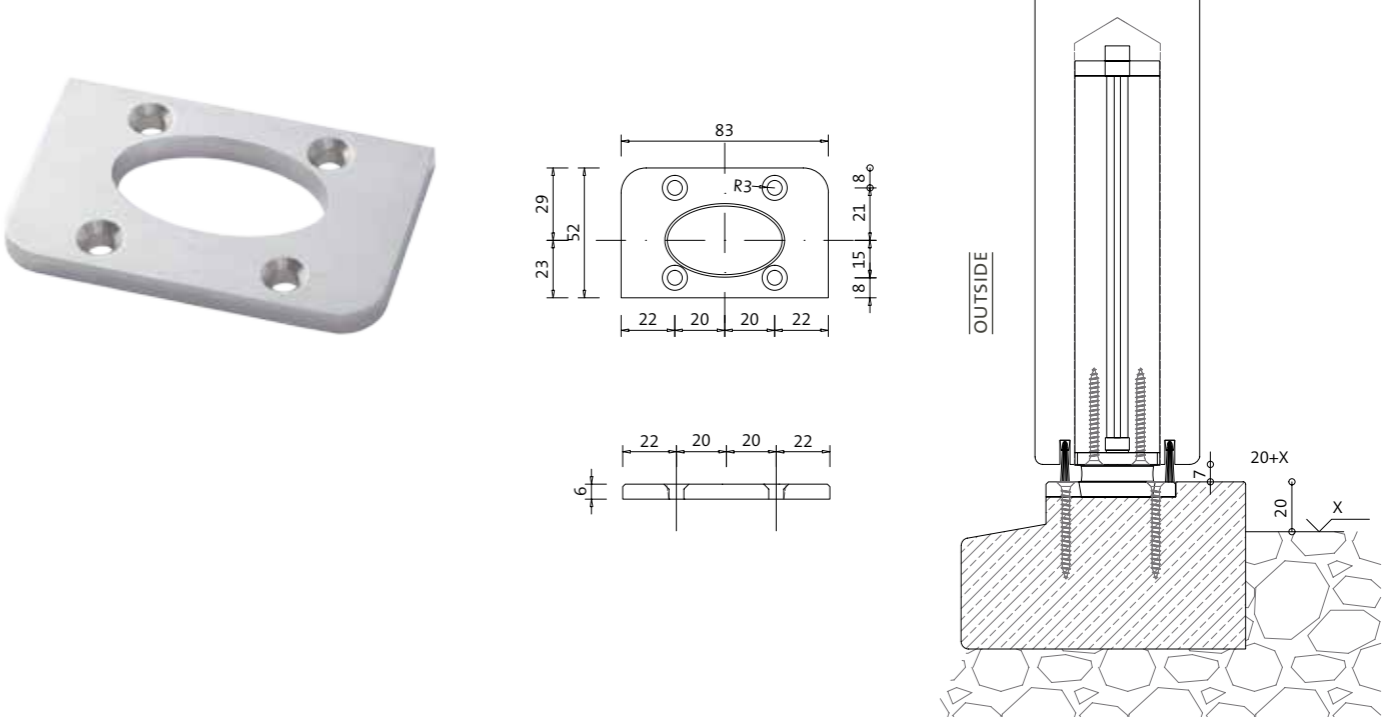



www.fritsjurgens.com

